

2800 5 Volt DC Water Sensor



2800
Surface Mount
Water Sensor

- Will detect any conductive non-flammable liquid
- Ideal anywhere water damage could occur
- Automatic Reset
- Available in gray only
- 6 foot jacketed lead standard
- Custom lead lengths available

Undetected water damage such as that caused by leaking pipes or corroded water heaters cost homeowners ten's of thousands of dollars each year. Such repairs are time consuming and costly to correct. Applications could include computer room sub-floor areas, telephone equipment rooms, bathrooms, laundry rooms, any areas adjacent to a water storage tank or piping. Also evaporative air conditioners, drip pans, overflows and/or drains.

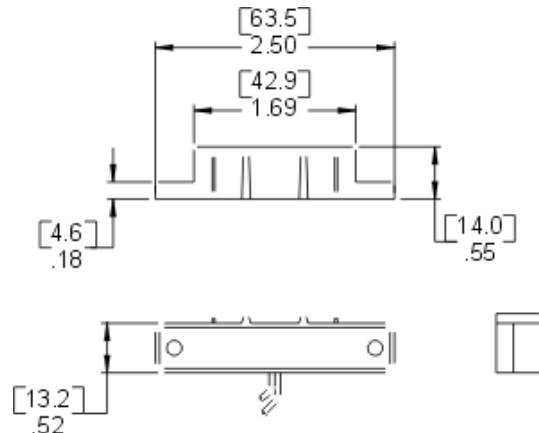

2800 Surface Mount Water Sensor

SURFACE MOUNT WATER SENSOR

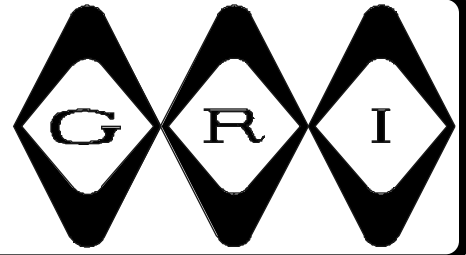

- ◆ Will Detect Any Conductive Non-Flammable Liquid
- ◆ Ideal Anywhere Water Damage Could Occur
- ◆ Automatic Reset
- ◆ Available In Gray Only
- ◆ 6 Foot Jacketed Lead Standard
- ◆ Custom Lead Lengths Available
- ◆ For Maximum Protection We Recommend
Using the 2600 4-Wire Sensor



2800

Undetected water damage, such as that caused by leaking pipes or corroded water heaters, cost homeowners tens of thousands of dollars each year. Such repairs are time consuming and costly to correct. Applications could include computer room sub-floor areas, telephone equipment rooms, bathrooms, laundry rooms, any areas adjacent to a water storage tank or piping. Also evaporative air conditioners, drip pans, overflows and/or drains.

Using no mechanical parts, the GRI Water Sensors are triggered by a moisture bridge across the sensor contacts. The GRI Water Sensors can be installed to detect a layer of water as minute as 1/16 of an inch in depth.

Requiring only two wires for signal and power, the GRI 2800 Water Sensor utilizes an open collector electronic trigger. The sensor simulates a simple dry closure. It can be used to activate a remote signaling device or it can be wired directly to most alarm panels and some wireless transmitters.

The G.R.I. Water Sensors will continue to protect against troublesome and costly water leaks for years to come.

PART NUMBERS:

	Configuration
2800	Normally Open For an Open Loop Circuit 5-24 Volts DC

2800 OPEN LOOP SPECIFICATIONS:

Power Requirements:

Operating Voltage (min./max.)	5-24 Volts DC
Standby Current (at max. voltage)	10 uA
Alarm Current (max.)	400 mA

Wire Contacts:

Red Wire	+5-24 Volts DC
Black Wire	- Ground

Contact Characteristics:

Contacts	Normally Open
----------	---------------

GEORGE RISK INDUSTRIES, INC.
GRI PLAZA
KIMBALL, NE 69145



MADE IN U.S.A.

TOLL-FREE 1-800-445-5218
TOLL-FREE 1-800-523-1227
(308) 235-4645
FAX (308) 235-3561
E-MAIL: grisales@megavision.com
WEB SITE: www.grisk.com

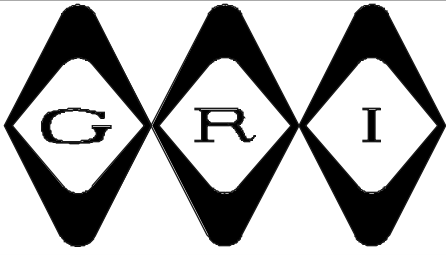

SURFACE MOUNT WATER SENSOR

INSTALLATION INSTRUCTIONS:

MINIMUM 5VDC REQUIRED

THIS IS AN EXTREMELY IMPORTANT TECHNICAL ADVISORY FROM GRI: If there is insufficient power to properly operate this device, the ability of the security system to sense the presence of water will be compromised. The 2800 is a normally open switch for an open loop application. The 2800 requires a DC operating voltage on the zone loop of a **5VDC minimum to a maximum 24VDC**. If there is an EOL resistor installed, measure to confirm the 5VDC minimum for the zone loop. (In the event the panel does not provide the minimum DC voltage, refer to the drawing at the right for installation). After installation these units should be tested with water and inspected annually. If there is any corrosion or damage the sensor should be replaced.

FOR INSTALLATION TO THE CONTROL PANEL

Select the open loop where the switch will be connected. The switch must be connected with the correct polarity. If the panel terminal strip is not marked, zone polarity can be determined by using a test volt meter. **The panel must be capable of producing a minimum of 5 Volts DC under load to the sensor.** Connect the red lead to the positive side of the panel zone and the black lead to the returning negative side. (If the panel does not provide minimum power for the 2800 use the wiring diagram at the right showing the use of a sensitive relay board and the auxiliary power from the BACP.)

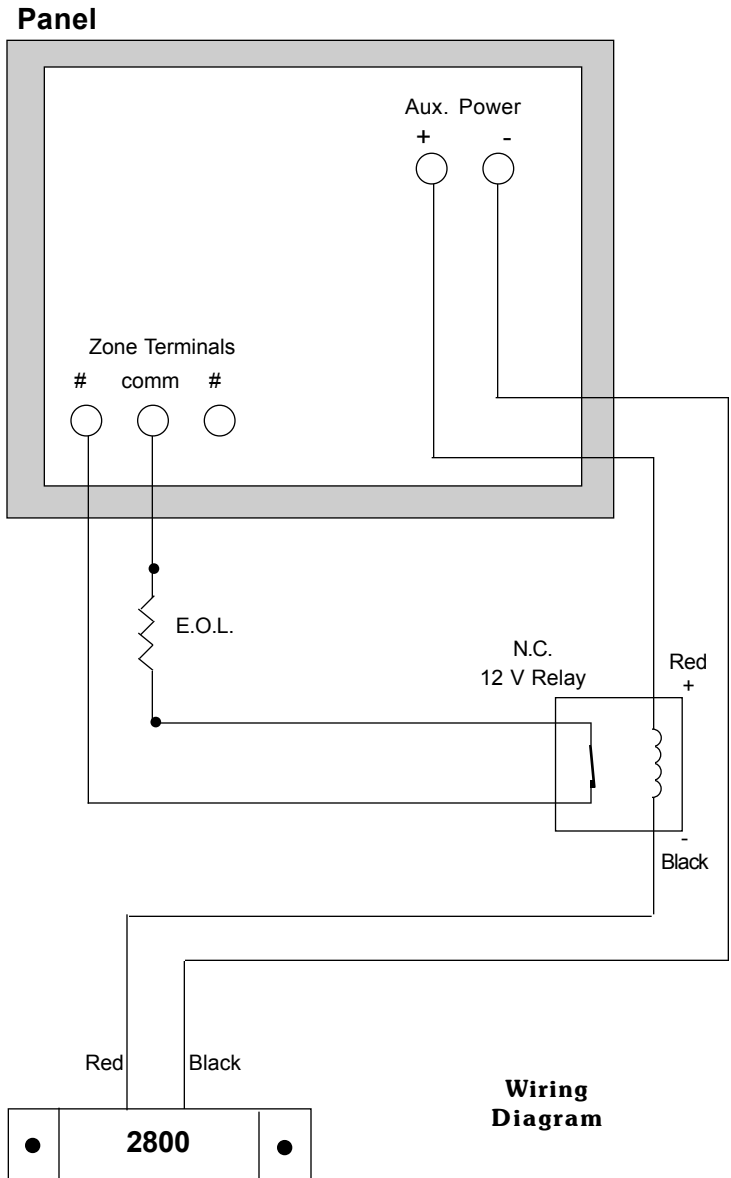
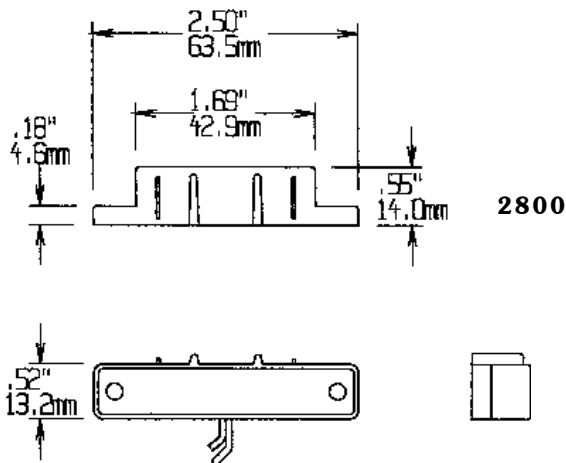

WARRANTY:

One year warranty against workmanship, material and factory defects.

GEORGE RISK INDUSTRIES, INC.
G.R.I. PLAZA
KIMBALL, NE 69145



MADE IN U.S.A.

TOLL-FREE 1-800-445-5218
TOLL-FREE 1-800-523-1227
(308) 235-4645
FAX (308) 235-3561

E-MAIL: grisales@megavision.com
WEB SITE: www.grisk.com

2800 INSTALLATION INSTRUCTIONS

THIS IS AN EXTREMELY IMPORTANT TECHNICAL ADVISORY FROM GRI: If there is insufficient power to properly operate this device, the ability of the security system to sense the presence of water will be compromised.

MINIMUM 5VDC REQUIRED

The 2800 is a normally open switch for an open loop application. The 2800 requires a DC operating voltage on the zone loop of a **5VDC minimum to a maximum 24VDC**. **If there is an EOL resistor installed, measure to confirm the 5VDC minimum for the zone loop.** (In the event the panel does not provide the minimum DC voltage, refer to the drawing at the right for installation). For maximum protection we recommend using the 2600 4-wire sensor.

FOR INSTALLATION TO THE CONTROL PANEL

Select the open loop where the switch will be connected. The switch must be connected with the correct polarity. If the panel terminal strip is not marked, zone polarity can be determined by using a test volt meter. The panel must be capable of producing a minimum of 5 Volts DC under load to the sensor. Connect the red lead to the positive side of the panel zone & the black lead to the returning negative side. (If the panel does not provide minimum power for the 2800 use the wiring diagram at the right showing the use of a sensitive relay board & the auxiliary power from the Burglar Alarm Control Panel.) After installation these units should be tested with a damp sponge or paper towel & inspected annually. If there is any corrosion or damage the sensor should be replaced.

Proof of Purchase required with return.

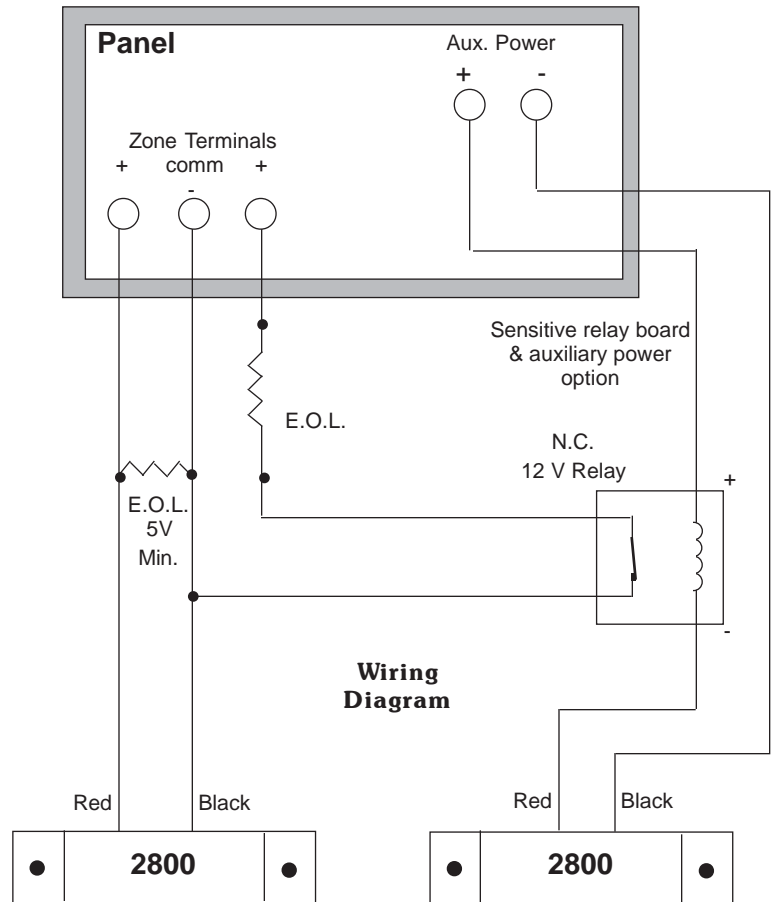



GEORGE RISK INDUSTRIES, INC.

802 S. ELM ST., KIMBALL, NEBRASKA 69145-1599

TELEPHONE (308) 235-4645

KEYBOARDS SALES FAX # (308) 235-2609

SECURITY SALES FAX # (308) 235-3561

E-MAIL: grisales@megavision.com

WEB SITE: www.grisk.com

Technical Bulletin No. TB28001

Using the G.R.I. 2800 series Water Sensor in conjunction with panels, utilizing low voltage zone loops.

Please note there are panels manufactured that use a lower voltage level on their zone loops. A voltage reading taken directly across the zone should confirm these panels. Normally, a reading of 7.8 to 6 volts or less will be noted indicating this panel type. Application of the EOL resistor would typically further reduce the voltage available on the zone loop to less than half the total voltage.

The G.R.I. 2800 Water Sensor is an open loop device designed to operate most efficiently using a recommended minimum voltage of 5VDC to a maximum of 24VDC. Most panels will require installation of an EOL resistor in a parallel configuration to the G.R.I. 2800 to correctly monitor the open loop. On a low voltage panel, the EOL will further limit the working voltage for the G.R.I. 2800 to less than the recommended 5 volts required to perform a positive and relatively rapid on/off operation.

Before installation of the G.R.I. 2800 directly to the panel zone, please confirm a minimum voltage of 5VDC after the EOL resistor. Panels not meeting these minimum voltage criteria should have the G.R.I. 2600 series Closed Loop, 4 wire sensor installed to insure a positive and reliable switching function.

On all installations of extreme sensitive nature dealing with equipment like the G.R.I. 2800 and 2600 Water Sensors, it is recommended that the sensors be routinely tested for normal operation no less than once per 12 month period.

FOR FURTHER ASSISTANCE, PLEASE CALL YOUR G.R.I. TECHNICAL SUPPORT REPRESENTATIVE.